

- ALUMINUM CONSTRUCTION
- ADJUSTABLE TOP
- 200LB DRAWER SLIDES
- PLUS 2" INSTALL FEET
- 4X DIVIDERS PER DRAWER (OPTIONAL)

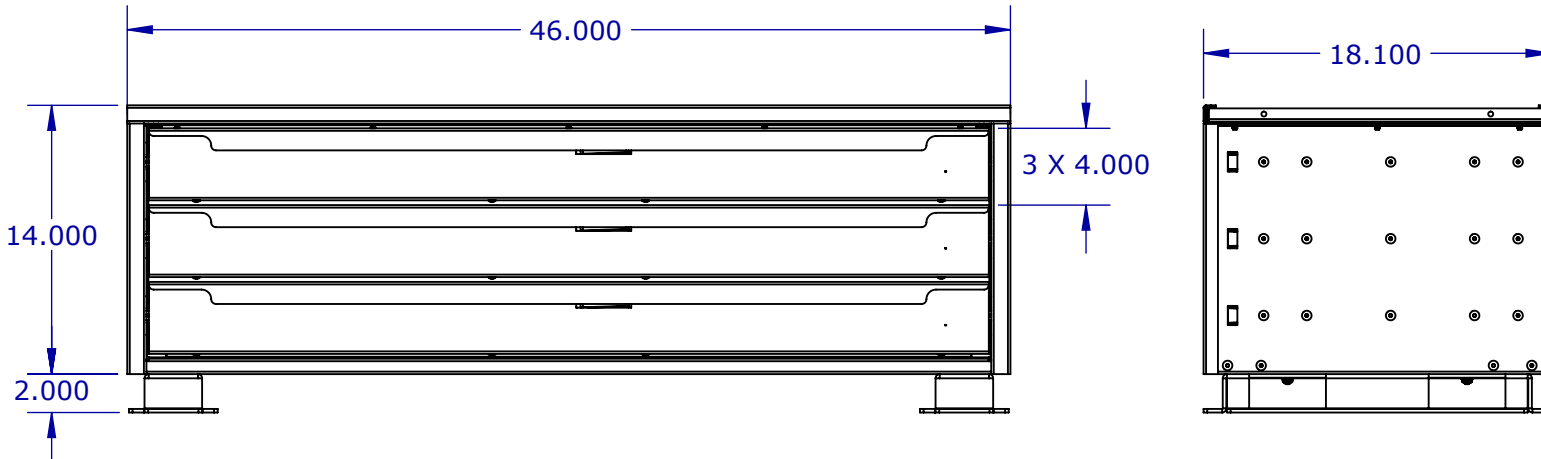

ITEM NO.	PART NUMBER	DESCRIPTION	QTY.	Revision
1	1129880	SERVICE DRAWER CABINET ASSEM	1	01
2	1129889	DRAWER ASSEMBLY - 4"H	3	-

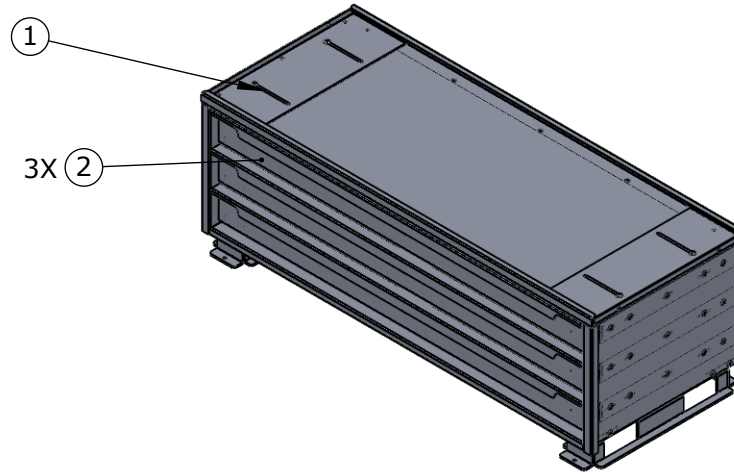

PH:(613)530.3419
FAX:(613)546.5489

DESCRIPTION
SERVICE DRAWER UNIT

PART NO.
SD-144618-002

	NAME	DATE
DRAWN	VS	01/18/18
CHECKED	DDR	Jan 18, 2018
RELEASED TO PRODUCTION		

PROPERTIES

MATERIAL: ALUMINIUM
THICKNESS: N/A
FINISH: NONE
WEIGHT: 100.169 LB

TOLERANCES UNLESS OTHERWISE SPECIFIED:

X.X ± 0.025
X.XX ± 0.010
X.XXX ± 0.005

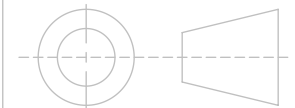

DO NOT SCALE DRAWING

PROPRIETARY AND CONFIDENTIAL

THE INFORMATION CONTAINED IN THIS DRAWING IS THE SOLE PROPERTY OF EZSTAK LLC. ANY REPRODUCTION IN PART OR AS A WHOLE WITHOUT THE WRITTEN PERMISSION OF EZSTAK LLC IS PROHIBITED.

SIZE **A** REV **01**

SCALE: 1:10 SHEET 1 OF 1

UNIT: IPS

Deburr All Edges