

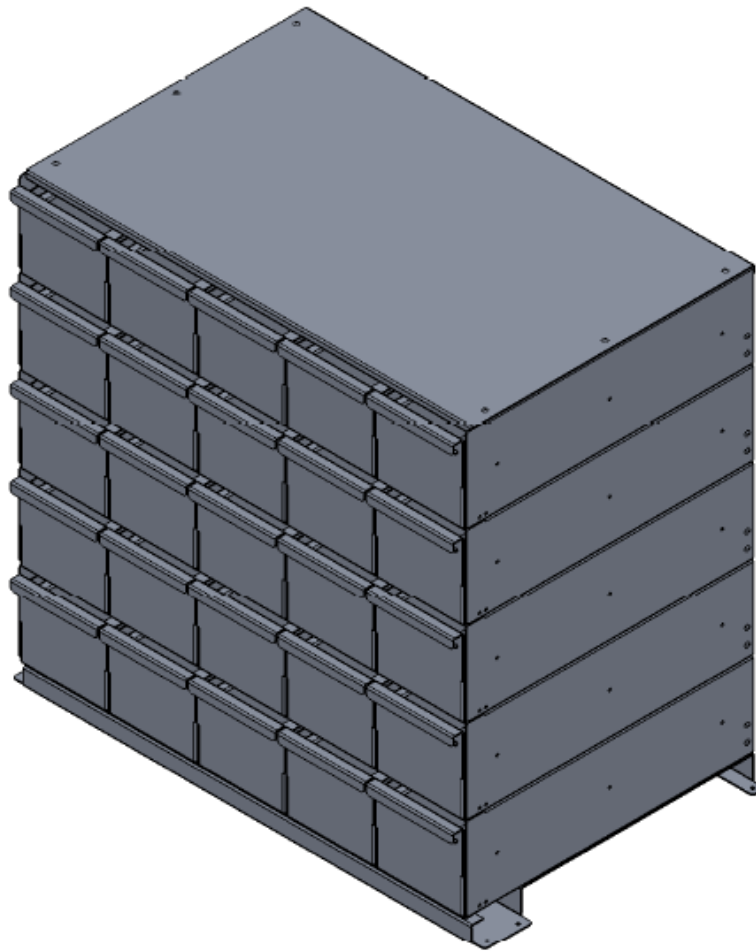

USER GUIDE

Bin Unit

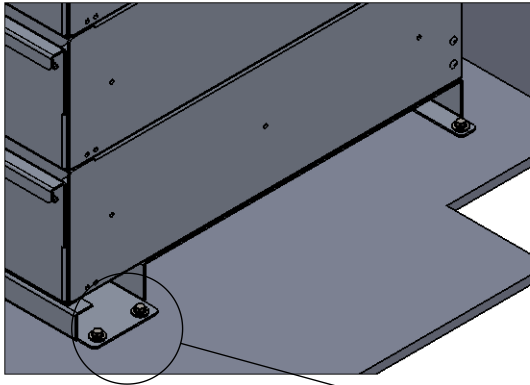



STEP 1:
ALIGN BOLT BIN WITH WALL AND SECURE UNIT TO FLOOR USING 6 SELF-TAPPING ¼" SCREWS AND FLAT WASHERS.

ENSURE SCREWS WILL NOT DAMAGE FUEL TANKS, FUEL LINES, BRAKE LINES, WIRING, ETC.

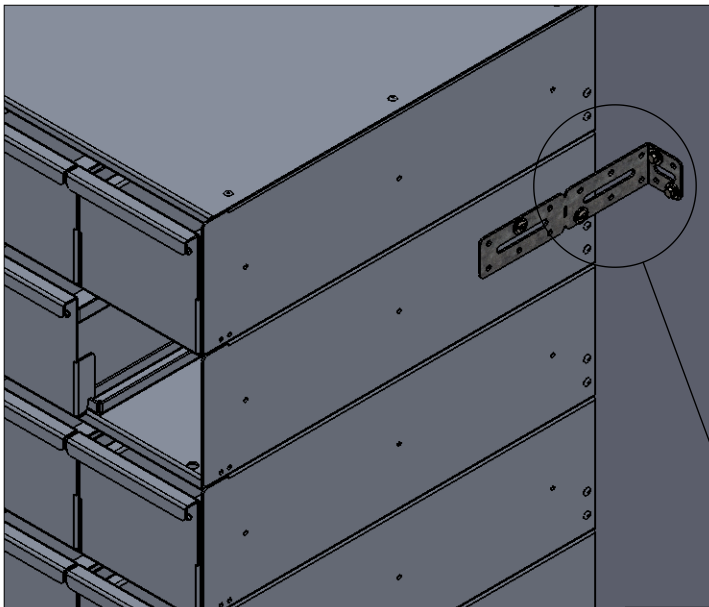
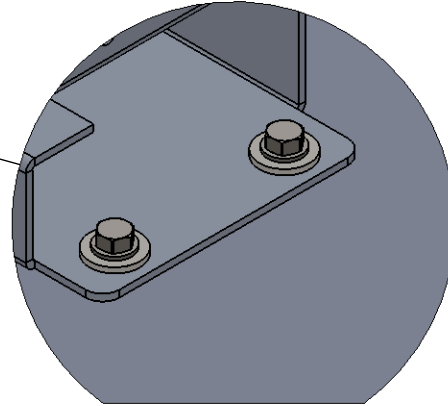

STEP 2:
USE A STRAIGHT 90° ANGLE BRACKET TO SECURE THE UNIT TO THE SIDE WALL OF THE VEHICLE. USE ¼" SELF-TAPPING SCREWS WITH FLAT WASHERS TO FASTEN TO THE WALL. ENSURE THAT BRACKET LOCATION STILL ALLOWS FOR BINS TO PULL OUT AND SCREWS WILL NOT DAMAGE FUEL TANKS, FUEL LINES, BRAKE LINES, WIRING, ETC.

STEP 3:
REMOVE A BIN TO ACCESS THE INSIDE OF THE CABINET AND DRILL HOLES FOR THE FASTENERS. USE ¼-20 TRUSS HEAD BOLTS, FLAT WASHERS, AND NYLOC NUTS TO ATTACH TO THE CABINET

